

FRONT SEAT SHOULDER STRAP INSTALLATION INSTRUCTIONS

ALL CONVERTIBLE STYLES

QUARTER ANCHORAGE

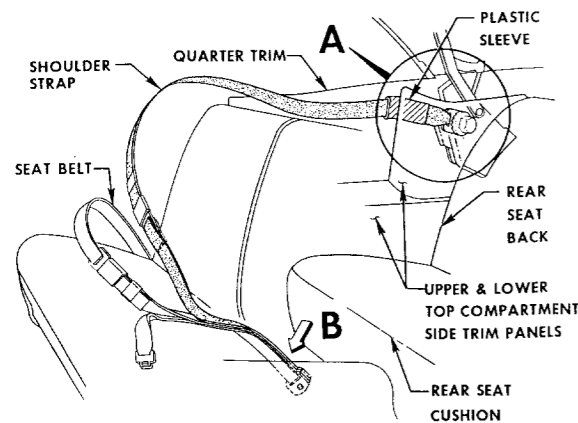

- 1 TO INSTALL FRONT SEAT SHOULDER STRAP TO CONVERTIBLE QUARTER AREA, REMOVE REAR SEAT BACK AND SEAT CUSHION. REMOVE UPPER AND LOWER TOP COMPARTMENT SIDE TRIM PANELS.
- 2 EXAMINE VIEW A CAREFULLY. LOCATE SPECIFIC BOLT USED IN YOUR CAR OR LOCATION OF NEW BOLT, IF APPLICABLE.
- 3 REMOVE EXISTING HINGE ANCHOR BOLT WHEN NECESSARY.
- 4 SECURE SHOULDER STRAP TO HINGE SUPPORT AS SHOWN WITH EXISTING OR NEW ANCHOR BOLT.
- 5 INSTALL UPPER AND LOWER TOP COMPARTMENT SIDE TRIM PANELS MAKING SURE THAT THE PROTECTIVE SLEEVE IS POSITIONED BETWEEN SIDE TRIM PANELS AND QUARTER TRIM.

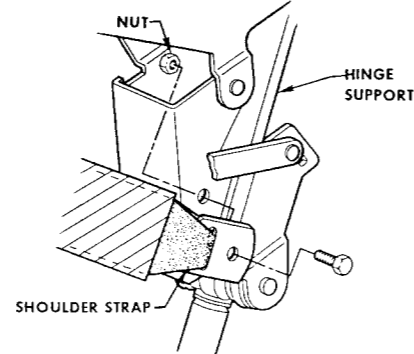

CHEVROLET IMPALA
PONTIAC CATALINA, GRAND PRIX & BONNEVILLE
OLDSMOBILE EIGHTY EIGHT & NINETY EIGHT
BUICK LA SABRE, WILDCAT, & ELECTRA "225"
CADILLAC DE VILLE

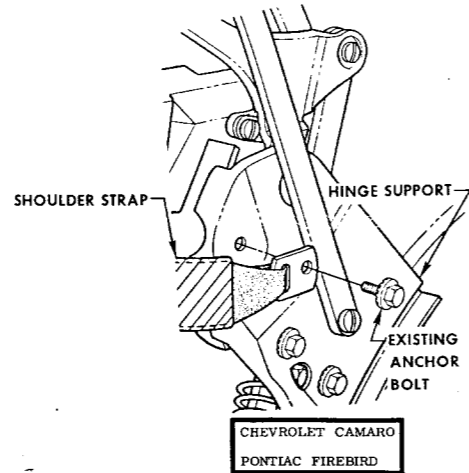

CHEVROLET CAMARO
PONTIAC FIREBIRD

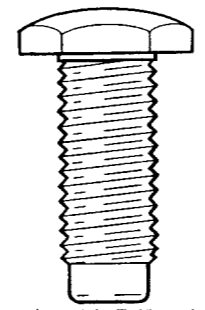

1/2" 13 THREAD
NO SHOULDER

VIEW A

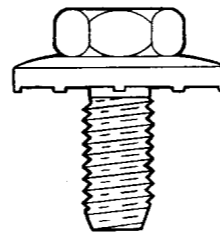

3/8" 16 THREAD

VIEW A

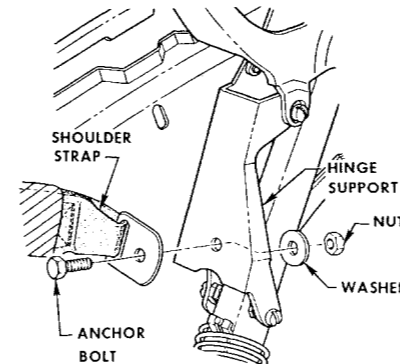

CHEVROLET CHEVELLE
PONTIAC TEMPEST, LEMANS & GTO
OLDSMOBILE F85, CUTLASS & 442
BUICK SKYLARK & GRAN SPORT

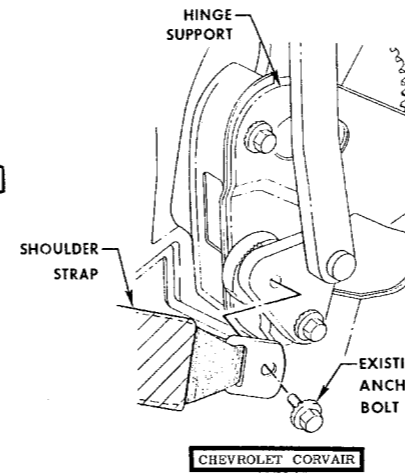

CHEVROLET CORVAIR

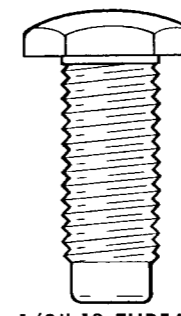

1/2" 13 THREAD
NO SHOULDER

VIEW A

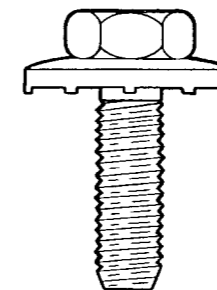

3/8" 16 THREAD

VIEW A

FLOOR ANCHORAGE

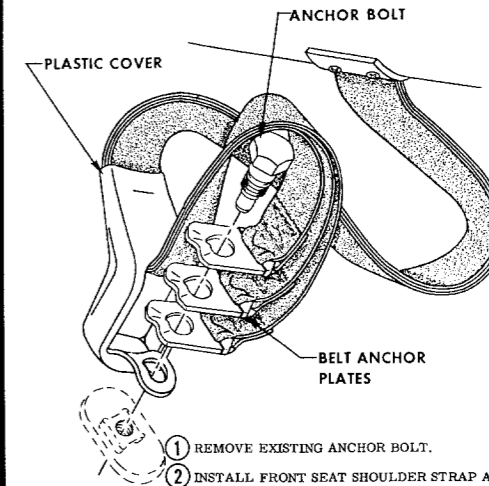

- 1 REMOVE EXISTING ANCHOR BOLT.
- 2 INSTALL FRONT SEAT SHOULDER STRAP AS SHOWN IN VIEW B.

NOTE: CHECK POSITION OF FACTORY INSTALLED BELT ANCHORS AND INSTALL NEW BELT AND ANCHOR PLATES IN SAME POSITION. CARE MUST BE EXERCISED WHEN MAKING INSTALLATION THAT ALL BELT ANCHOR PLATES INTER-LOCK AS SHOWN.

- 3 ON BUCKET TYPE SEAT REPLACE EXISTING ANCHOR BOLT THROUGH BELT ANCHOR PLATES AND SECURE TO FLOOR. ON BENCH TYPE SEAT USE NEW 1/2 INCH X 13 UNC - 2A BOLT WITH 13/16" SHOULDER PROVIDED.

NOTE: FOR INSTRUCTIONS ON REMOVAL AND INSTALLATION OF ALL SEAT CUSHIONS, SEAT BACKS AND TRIM PANELS NECESSARY TO PERFORM OPERATIONS DESCRIBED ON THIS SHEET, REFER TO 1969 COPY OF THE FISHER BODY SERVICE MANUAL AVAILABLE AT YOUR G.M. DEALER.

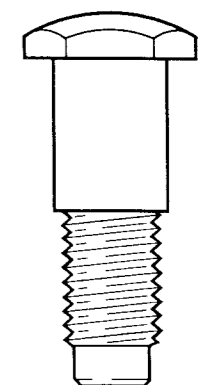

1/2" 13 THREAD
13/16" SHOULDER

VIEW B

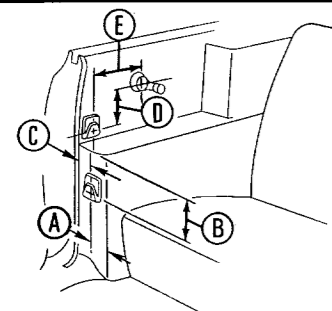

NOTE-

- 1 EXAMINE THIS SHEET CAREFULLY, AND LOCATE THE STYLE AND DIMENSION FOR LOCATING THE RETAINER IN YOUR CAR.
- 2 DRILL TWO (2) 1/8" HOLES AND SECURE RETAINER TO BODY.

BUCKLE RETAINER

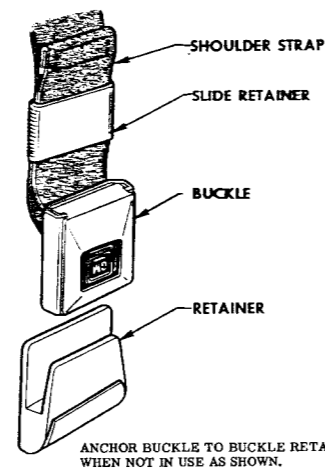
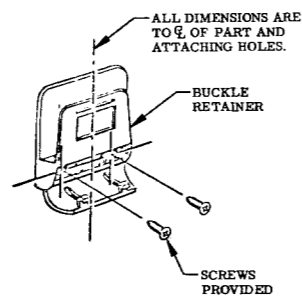

BELT ADJUSTMENT

DELUXE BUCKLE SHOWN STANDARD TYPICAL

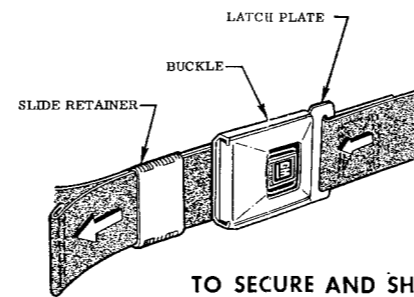

TO SECURE AND SHORTEN

WITH BUCKLE SECURE, ADJUST THE BELT FIRMLY TO YOUR HIPS BY PULLING ON THE LOOSE END OF WEBBING PROTRUDING FROM THE BUCKLE.

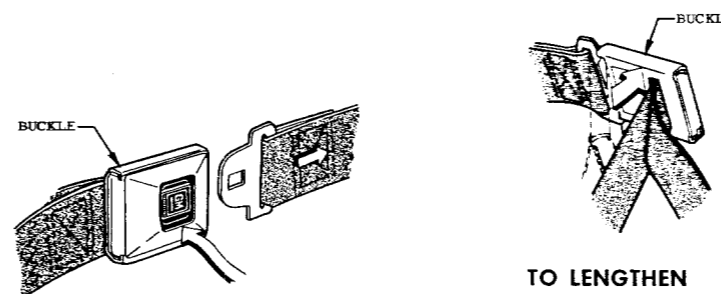

TO LENGTHEN

TO UNLATCH

TO RELEASE BELT, DEPRESS BUTTON ON BUCKLE.

TO ENLARGE THE BELT, LIFT BUCKLE APPROXIMATELY 90 DEGREES TO THE WEBBING AND PULL ON BUCKLE TO DESIRED LENGTH.

STYLES	DIMENSION				
	A	B	C	D	E
CHEVROLET CAMARO PONTIAC FIREBIRD	4	6 1/2			
CHEVROLET CHEVELLE PONTIAC TEMPEST, LEMANS & GTO OLDSMOBILE F85, CUTLASS & 442 BUICK SKYLARK & GRAN SPORT	3 1/8	8 1/4			
CHEVROLET IMPALA PONTIAC CATALINA, BONNEVILLE & GRAND PRIX OLDSMOBILE EIGHTY EIGHT & NINETY EIGHT BUICK LA SABRE, WILDCAT & ELECTRA "225"	2 7/16	8 3/8			
CADILLAC DE VILLE CHEVROLET CORVAIR MONZA		11 1/8	2	5 1/8	4 7/8

GENERAL INFORMATION

THIS UPPER TORSO RESTRAINT IS TO BE USED ONLY IN CONJUNCTION WITH A LAP BELT. NEVER USE THE SHOULDER STRAP ALONE.

SHOULDER STRAPS NOT IN USE MUST BE ANCHORED BY INSERTING BUCKLE INTO RETAINER LOCATED ON BODY PILLAR TO PREVENT BUCKLE END LASHING ABOUT.

SHOULDER STRAPS ARE RECOMMENDED ONLY FOR PERSONS OVER 4 FEET 7 INCHES IN HEIGHT.

PROPER USE AND CARE OF YOUR SHOULDER STRAPS AND SEAT BELTS WILL PROVIDE ADDED SECURITY TO DRIVER AND PASSENGERS.

- 1 INSERT THE LATCH PLATE INTO THE OPEN END OF THE BUCKLE UNTIL AN AUDIBLE SNAP IS HEARD.
- 2 ADJUST BELT BY PULLING ON THE LOOSE END OF WEBBING PROTRUDING FROM THE BUCKLE.
SEAT BELTS SHOULD BE ADJUSTED FIRMLY, LOW ON THE HIPS. SHOULDER STRAPS SHOULD HAVE SUFFICIENT SLACK TO ALLOW A HAND'S WIDTH TO BE INSERTED FREELY BETWEEN THE BELT AND CHEST.
- 3 TO ENLARGE THE BELT, TILT BUCKLE TO APPROXIMATELY 90 DEGREES TO THE WEBBING AND PULL ON BUCKLE TO DESIRED LENGTH.
- 4 KEEP SHARP EDGES AND DAMAGING OBJECTS AWAY FROM BELTS.

NOTE: AVOID THE FOLLOWING CONDITIONS

- a. WEARING SEAT BELTS LOOSELY OR SHOULDER STRAPS SNUG
- b. BLEACHING OR RE-DYING WEBBING (CLEAN WITH A MILD SOAP SOLUTION AND WATER)
- c. MORE THAN ONE PERSON PER BELT SET (SEAT & SHOULDER)
- d. WEARING A TWISTED BELT

ATTENTION DEALERS

PLACE THIS INSTRUCTION SHEET IN GLOVE BOX AFTER BELT INSTALLATION.

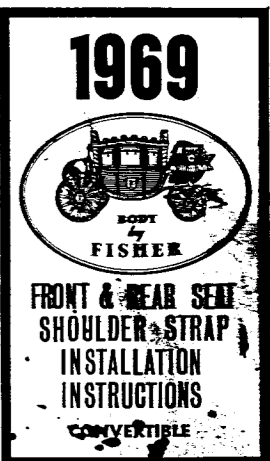

FISHER BODY ENGINEERING ACTIVITY

8701739