

1969 GENERAL MOTORS REAR SEAT SHOULDER STRAP INSTALLATION INSTRUCTIONS ALL CONVERTIBLE STYLES

ALL STYLES EXCEPT CORVAIR

EXCEPT CHEVROLET IMPALA & CADILLAC DE VILLE

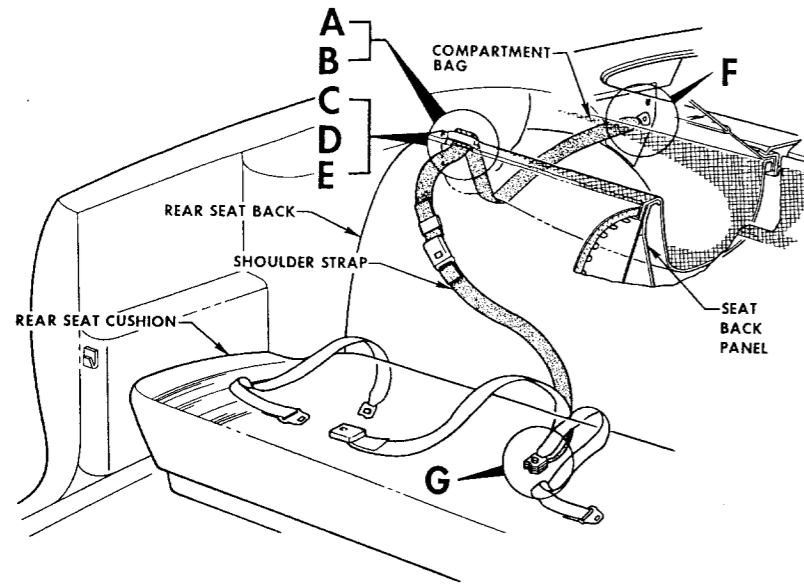

- 1 REMOVE REAR SEAT CUSHION AND REAR SEAT BACK.
- 2 STUDY VIEW C AND CHART CAREFULLY AND MEASURE INWARD FROM THE END OF REAR SEAT BACK PANEL DISTANCE X AND DRILL A 1/8" DIA. HOLE THRU COMPARTMENT BAG AND SEAT BACK PANEL. MEASURE OUTWARD FROM THE ABOVE DESCRIBED HOLE DISTANCE Y AND DRILL A SECOND 1/8" DIA. HOLE. SLIT COMPARTMENT BAG APPROXIMATELY 1/2" OUTWARD FROM EACH HOLE AS SHOWN IN VIEW C AND LOOSEN MATERIAL FROM FRONT EDGE OF SEAT BACK PANEL.
- 3 TURN UNDER LOOSE MATERIAL AND PLACE BETWEEN COMPARTMENT BAG AND SEAT BACK PANEL AS SHOWN IN VIEW D.
- 4 INSERT SHOULDER STRAP UNDER FOLDED PORTION OF COMPARTMENT BAG AND EXTEND TO ANCHOR PLATE ATTACHING AREA AND INSTALL AS SHOWN IN VIEW F.
- 5 POSITION PLASTIC SLEEVE BETWEEN COMPARTMENT BAG AND SEAT BACK PANEL AS SHOWN IN VIEW E AND INSTALL SCREWS.

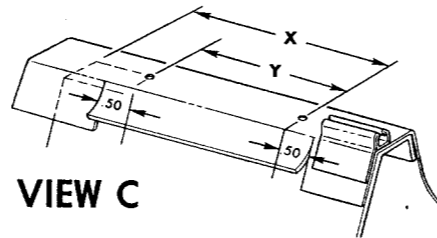

VIEW C

| STYLES | DIMENSION | |
|---|-----------|--------|
| | X | Y |
| CHEVROLET CAMARO | 4 5/8" | 3 1/2" |
| PONTIAC FIREBIRD | | |
| CHEVROLET CHEVELLE | | |
| PONTIAC TEMPEST, LEMANS & GTO | 5 3/8" | 3 1/2" |
| OLDSMOBILE F85, CUTLASS & 442 | | |
| BUICK SKYLARK & GRAN SPORT | | |
| PONTIAC CATALINA, BONNEVILLE & GRAND PRIX | | |
| OLDSMOBILE EIGHTY EIGHT & NINETY EIGHT | 5 5/8" | 3 1/2" |
| BUICK LE SABRE, WILDCAT & ELECTRA "225" | | |

CHEVROLET IMPALA & CADILLAC DE VILLE

- 1 REMOVE REAR SEAT CUSHION AND REAR SEAT BACK.
- 2 MEASURE 3 1/2" OUTWARD FROM THE END SCREW FASTENER AND DRILL A 1/8" DIA. HOLE THRU COMPARTMENT BAG AND SEAT BACK PANEL AS SHOWN IN VIEW A.
- 3 INSERT SHOULDER STRAP BETWEEN COMPARTMENT BAG AND SEAT BACK PANEL AND EXTEND TO ANCHOR PLATE ATTACHING AREA AND INSTALL AS SHOWN IN VIEW F.
- 4 POSITION PLASTIC SLEEVE BETWEEN COMPARTMENT BAG AND SEAT BACK PANEL AS SHOWN IN VIEW B AND INSTALL SCREW.

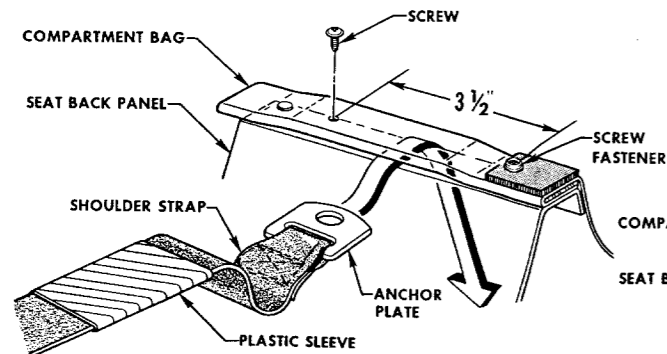

VIEW A

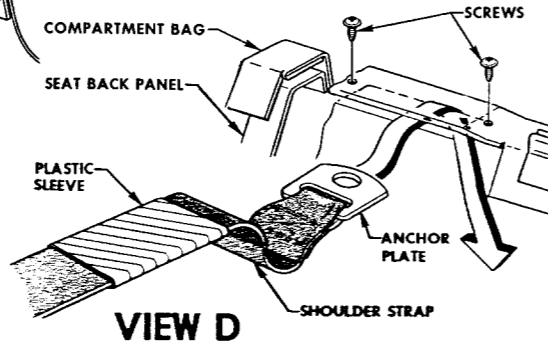

VIEW D

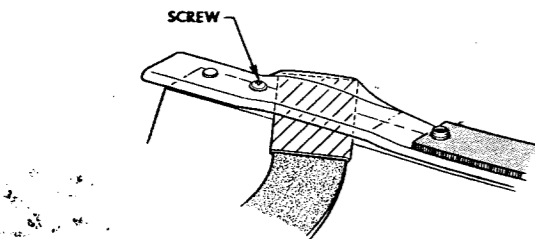

VIEW B

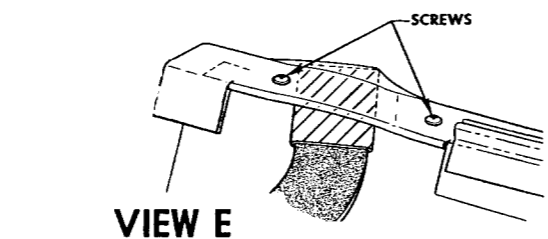

VIEW E

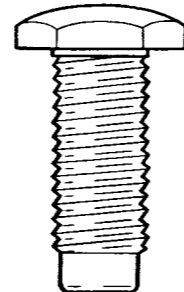

1/2" 13 THREAD
NO SHOULDER

CORVAIR STYLES

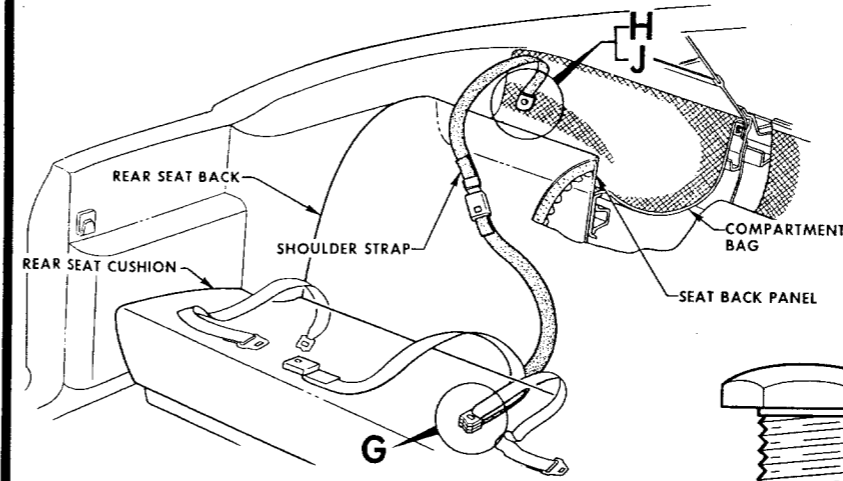

- 1 REMOVE REAR SEAT CUSHION AND REAR SEAT BACK.
- 2 REMOVE FORWARD EDGE OF COMPARTMENT BAG FROM THE SEAT BACK PANEL AND LIFT BAG EXPOSING JOINT OF SIDE AND CENTER FOLDING TOP PANELS.
- 3 LOCATE THE 3/16" DIA. PILOT HOLE USING DIMENSIONS SHOWN IN VIEW H AND DRILL 1/32" DIA. HOLE.
NOTE: IT MAY BE NECESSARY TO REMOVE EXCESS SEALING MATERIAL TO LOCATE PILOT HOLE IN FOLDING TOP SIDE PANEL.
- 4 LOWER COMPARTMENT BAG INTO NORMAL POSITION AND PIERCE HOLE IN BAG ADJACENT TO 17/32" DIA. HOLE IN FOLDING TOP PANELS AS SHOWN IN VIEW J.
- 5 WITH THE AID OF AN ASSISTANT INSTALL SHOULDER STRAP ANCHOR PLATE AND ATTACHING PARTS AS SHOWN IN VIEW J.
- 6 REPLACE FORWARD EDGE OF COMPARTMENT BAG TO SEAT BACK PANEL IN ITS ORIGINAL POSITION. (NOTE: TRIM CEMENT IS AVAILABLE AT YOUR G.M. DEALER.)

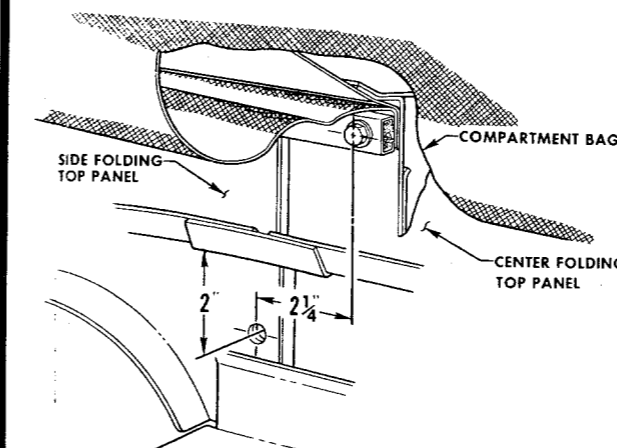

VIEW H

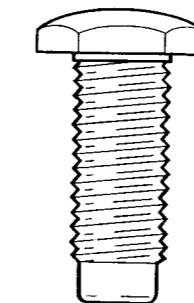

1/2" 13 THREAD
NO SHOULDER

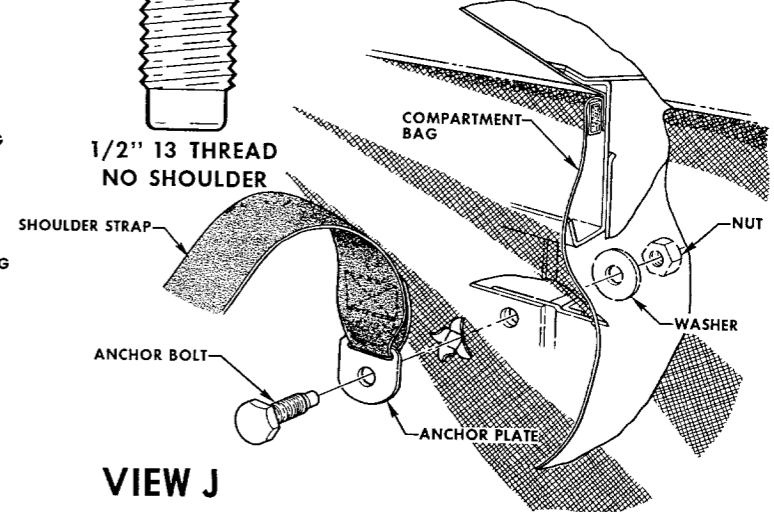

VIEW J

QUARTER ANCHORAGE

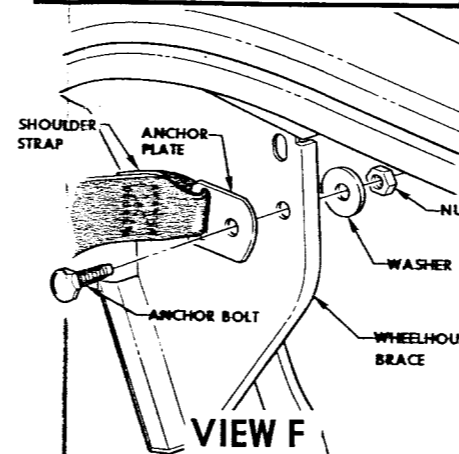

VIEW F

ALL STYLES EXCEPT CORVAIR

WORKING THRU LUGGAGE COMPARTMENT LOCATE THE WHEELHOUSE BRACE. ON SOME STYLES THIS AREA WILL BE FRIMMED REQUIRING REMOVAL OF A HINGE BOX COVER AND THE TURNING BACK OF THE FRONT PORTION OF COMPARTMENT SIDE TRIM PANEL. LOCATE THE 9/16" DIA. PIERCED HOLE IN THE WHEELHOUSE BRACE AND INSTALL SHOULDER STRAP ANCHOR PLATE AS SHOWN IN VIEW F.

NOTE: FOR INSTRUCTIONS ON REMOVAL AND INSTALLATION OF ALL SEAT CUSHIONS, SEAT BACKS AND TRIM PANELS NECESSARY TO PERFORM OPERATIONS DESCRIBED ON THIS SHEET, REFER TO 1969 COPY OF THE FISHER BODY SERVICE MANUAL AVAILABLE AT YOUR GM DEALER.

FLOOR ANCHORAGE

- 1 MAKE FLOOR ANCHORAGE ACCESSIBLE.
- 2 REMOVE EXISTING ANCHOR BOLT AND DISCARD.
- 3 INSTALL REAR SEAT SHOULDER STRAP AS SHOWN IN VIEW G.
- 4 INSERT NEW LONGER 1/2 INCH X 13 UNC-2A BOLT WITH 9/16 SHOULDER THROUGH BELT ANCHOR PLATES AND SECURE TO FLOOR ANCHORAGE.
- 5 REPLACE REAR SEAT CUSHION.

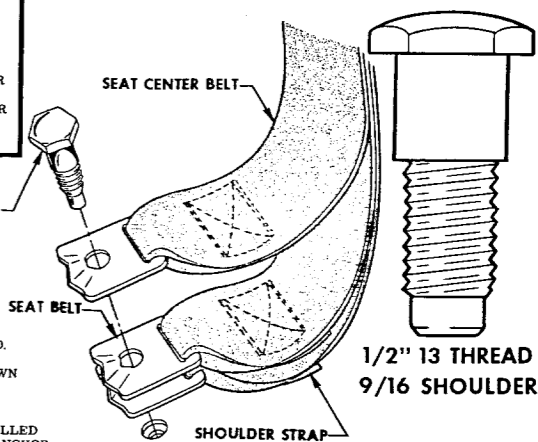

VIEW G
ALL STYLES

8701739